 Via Disraeli 8 42124 Reggio Emilia, Italy	DATASHEET	DSA10006			
	V30111100 CONTAINER VALVE	Rev.00		03/2017	
		Pag	1	of	1

Description

Pressure operated cylinder valve used in inert gas extinguishing systems. The valve is able to maintain the outlet pressure regulated at a pressure lower than 80 bar during the discharge of a 300 bar cylinder. The valve is intended for assembling on container and related accessories (manual/electrical actuator, pressure gauge assembly, pneumatic actuator).

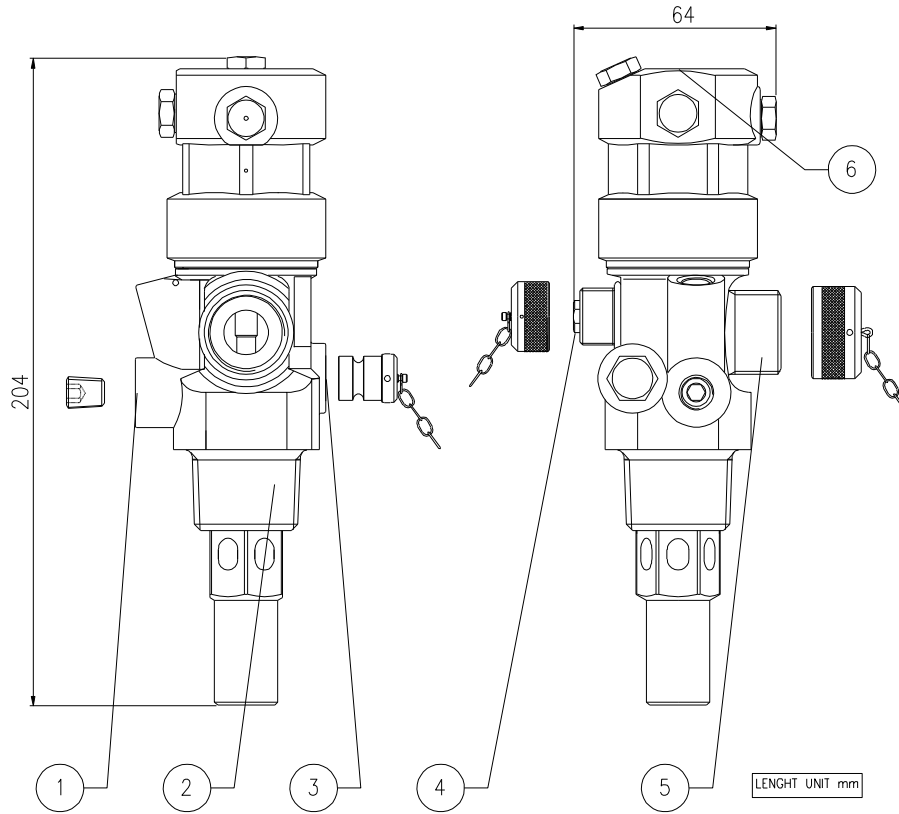

- | | |
|----------------------------------|---|
| 1. Re-filling connection | 4. Actuator/ pressure socket connection |
| 2. Inlet connection | 5. Outlet connection |
| 3. Pneumatic actuator connection | 6. Pilot connection |

Technical specification

Valve code.....V30111100	Approval..... CE marking (2014/68/UE, Reg. 305/2011 CPR)
Working pressure (WP).....370 bar	Accessories.....P3001xx00 pressure gauge, C3001xx00 manual/electric actuator, A001X0000
Service temperature.....-20 / +50 °C	Installation.....see specific system installation manual
Safety disc pressure.....410 bar	Maintenance.....see specific system operation and maintenance manual
Minimum/maximum container size.....5 / 180 L	
Extinguishing agent.....IG01,IG100,IG55,IG541	
Inlet connection.....1”NGT	
Outlet connection.....3/4” BSPP	
Pilot connection.....1/8” NPT	
Material.....brass, stainless steel, elastomer	